

NFC

(Varistor Type NFC)

Type NFC Varistors are made of semiconductor ceramic materials composed mainly of zinc oxide. They have non-linear resistance that changes as a function of applied voltage. It has small size, high current capacity, and high protection level.

1. Features

- Wide Varistor voltage range (18V ~1800V)
- Excellent non-linearity and protection level
- Large withstanding surge current
- Fast response ($\leq 20\text{ns}$)

2. Recommended Applications

- Protection of semiconductors
- Surge protection of consumer equipment
- Surge protection of communication, measuring or controller instrument
- Relay or electromagnetic Valve surge absorption

3. Explanation of Part numbers

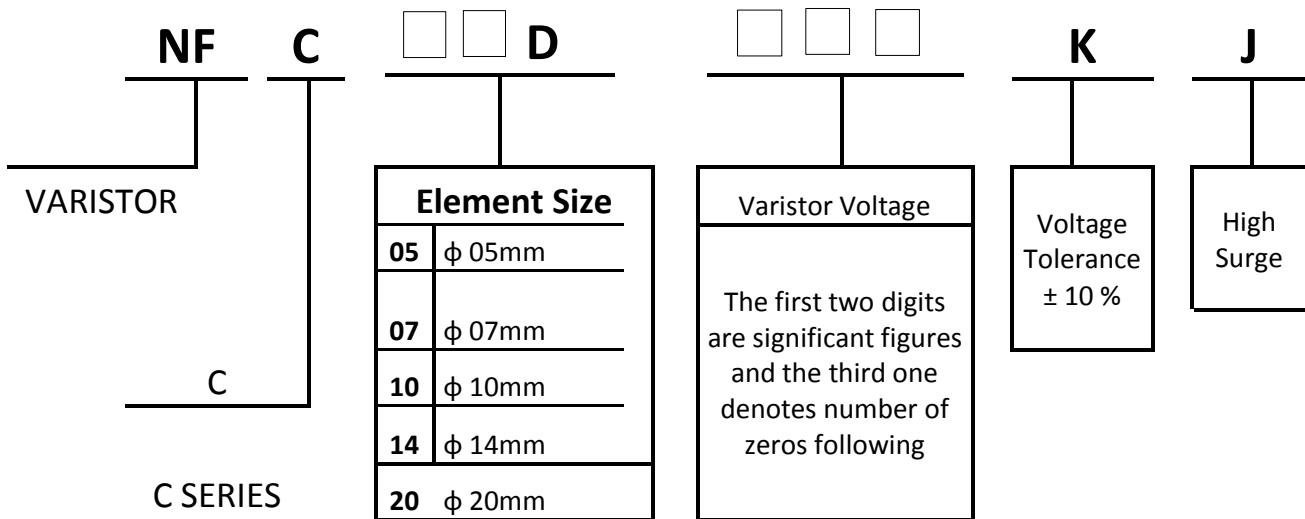

4. Specification and Electrical Characteristics

STANDARD	VARISTOR VOLTAGE	MAX. CONTINUOUS VOLTAGE		MAX. CLAMPING VOLTAGE		ENERGY (J)	MAX. PEAK CURRENT 8/20 μ s (A)		Rated Power	Capacitance (Reference) (1KHZ)
		V	Acrms (V)	DC (V)	Vc (V)		Ip (A)	10/1000 μ s		
05D180K	18 (16 ~ 20)	11	14	40	1	0.4	100	50	0.01	1300
07D180K				36	2.5	0.9	250	125	0.02	2400
10D180K				36	5	2.1	500	250	0.05	4500
14D180K				36	10	4.0	1000	500	0.1	10000
20D180K				36	20	11	2000	1000	0.2	19000
05D220K	22 (20 ~ 24)	14	18	48	1	0.5	100	50	0.01	1000
07D220K				43	2.5	1.1	250	125	0.02	2000
10D220K				43	5	2.5	500	250	0.05	3500
14D220K				43	10	5.0	1000	500	0.1	8500
20D220K				43	20	14	2000	1000	0.2	16000
05D270K	27 (24 ~ 30)	17	22	60	1	0.6	100	50	0.01	850
07D270K				53	2.5	1.4	250	125	0.02	1600
10D270K				53	5	3.0	500	250	0.05	3000
14D270K				53	10	6.0	1000	500	0.1	7000
20D270K				53	20	18	2000	1000	0.2	14500
05D330K	33 (30 ~ 36)	20	26	73	1	0.8	100	50	0.01	700
07D330K				65	2.5	1.7	250	125	0.02	1300
10D330K				65	5	4.0	500	250	0.05	2500
14D330K				65	10	7.5	1000	500	0.1	6000
20D330K				65	20	23	2000	1000	0.2	13000
05D390K	39 (35 ~ 43)	25	31	86	1	0.9	100	50	0.01	600
07D390K				77	2.5	2.1	250	125	0.02	1200
10D390K				77	5	4.6	500	250	0.05	2000
14D390K				77	10	8.6	1000	500	0.1	4800
20D390K				77	20	26	2000	1000	0.2	12000
05D470K	47 (42 ~ 52)	30	38	104	1	1.1	100	50	0.01	500
07D470K				93	2.5	2.5	250	125	0.02	1100
10D470K				93	5	5.5	500	250	0.05	1500
14D470K				93	10	10	1000	500	0.01	3800
20D470K				93	20	33	2000	1000	0.2	11000
05D560K	56 (50 ~ 62)	35	45	123	1	1.3	100	50	0.01	400
07D560K				110	2.5	3.1	250	125	0.02	1000
10D560K				110	5	7.0	500	250	0.05	1350
14D560K				110	10	11	1000	500	0.1	3300
20D560K				110	20	41	2000	1000	0.2	9000
05D680K	68 (61 ~ 75)	40	56	150	1	1.6	100	50	0.01	330
07D680K				135	2.5	3.6	250	125	0.02	850
10D680K				135	5	8.2	500	250	0.05	1250
14D680K				135	10	14	1000	500	0.1	2700

STANDARD	VARISTOR VOLTAGE	MAX. CONTINUOUS VOLTAGE		MAX. CLAMPING VOLTAGE		ENERGY (J)	MAX. PEAK CURRENT 8/20 μ s (A)		Rated Power	Capacitance (Reference) (1KHZ)	
		V	Acrms (V)	DC (V)	Vc (V)		Ip (A)	10/100 μ s			1time
20D680K					135	20	46	2000	1000	0.2	7500
05D820K	82 (74 ~ 90)	50	65		145	5	2.5	400	200	0.1	250
07D820K					135	10	5.5	1250	600	0.25	460
10D820K					135	25	12	2500	1300	0.4	1000
14D820K					135	50	22	4500	2500	0.6	2100
20D820K					135	100	48	6500	4000	1.0	4800
05D101K	100 (90 ~ 110)	60	85		175	5	3.0	400	200	1.0	230
07D101K					165	10	6.5	1250	600	0.25	420
10D101K					165	25	15	2500	1300	0.4	920
14D101K					165	50	28	4500	2500	0.6	1900
20D101K					165	100	51	6500	4000	1.0	3900
05D121K	120 (108 ~ 132)	75	100		210	5	4.0	400	200	0.1	210
07D121K					200	10	7.8	1250	600	0.25	380
10D121K					200	25	18	2500	1300	0.4	830
14D121K					200	50	32	4500	2500	0.6	1700
20D121K					200	100	55	6500	4000	1.0	3300
05D151K	150 (135 ~ 165)	95	125		260	5	4.8	400	200	0.1	190
07D151K					250	10	9.7	1250	600	0.25	350
10D151K					250	25	22	2500	1300	0.4	760
14D151K					250	50	40	4500	2500	0.6	940
20D151K					250	100	70	6500	4000	1.0	1950
05D181K	180 (162 ~ 198)	115	150		315	5	5.9	400	200	0.1	70
07D181K					300	10	11.7	1250	600	0.25	155
10D181K					300	25	27	2500	1300	0.4	310
14D181K					300	50	52	4500	2500	0.6	800
20D181K					300	100	84	6500	4000	1.0	1620
05D201K	200 (180 ~ 220)	130	170		355	5	6.5	400	200	0.1	65
07D201K					340	10	13	1250	600	0.25	140
10D201K					340	25	30	2500	1300	0.4	290
14D201K					340	50	57	4500	2500	0.6	700
20D201K					340	100	95	6500	4000	1.0	1460
05D221K	220 (198 ~ 242)	140	180		380	5	7.0	400	200	0.1	60
07D221K					360	10	14	1250	600	0.25	130
10D221K					360	25	32	2500	1300	0.4	270
14D221K					360	50	60	4500	2500	0.6	640
20D221K					360	100	100	6500	4000	1.0	1320
05D241K	240 (216 ~ 264)	150	200		415	5	8.0	400	200	0.1	55
07D241K					395	10	15	1250	600	0.25	120

STANDARD	VARISTOR VOLTAGE	MAX. CONTINUOUS VOLTAGE		MAX. CLAMPING VOLTAGE		ENERGY (J)	MAX. PEAK CURRENT 8/20 μ s (A)		Rated Power	Capacitance (Reference) (1KHZ)	
		V	Acrms (V)	DC (V)	Vc (V)		Ip (A)	10/1000 μ s			1time
10D241K					395	25	35	2500	1300	0.4	240
14D241K					395	50	63	4500	2500	0.6	580
20D241K					395	100	108	6500	4000	1.0	1200
05D271K	270 (243 ~ 297)	175	225	475	5	8.5	400	200	0.1	50	
07D271K				455	10	18	1250	600	0.25	110	
10D271K				455	25	40	2500	1300	0.4	230	
14D271K				455	50	70	4500	2500	0.6	520	
20D271K				455	100	127	6500	4000	1.0	1100	
05D331K	330 (297 ~ 363)	210	275	580	5	9.2	400	200	0.1	45	
07D331K				550	10	23	1250	600	0.25	100	
10D331K				550	25	43	2500	1300	0.4	200	
14D331K				550	50	85	4500	2500	0.6	450	
20D331K				550	100	150	6500	4000	1.0	950	
05D361K	360 (324 ~ 396)	230	300	620	5	10	400	200	0.1	45	
07D361K				595	10	25	1250	600	0.25	95	
10D361K				595	25	47	2500	1300	0.4	190	
14D361K				595	50	93	4500	2500	0.6	430	
20D361K				595	100	163	6500	4000	1.0	900	
05D391K	390 (351 ~ 429)	250	320	675	5	12	400	200	0.1	40	
07D391K				650	10	25	1250	600	0.25	85	
10D391K				650	25	60	2500	1300	0.4	175	
14D391K				650	50	100	4500	2500	0.6	390	
20D391K				650	100	180	6500	4000	1.0	800	
05D431K	430 (387 ~ 473)	275	350	745	5	13	400	200	0.1	35	
07D431K				710	10	28	1250	600	0.25	80	
10D431K				710	25	65	2500	1300	0.4	160	
14D431K				710	50	115	4500	2500	0.6	370	
20D431K				710	100	190	6500	4000	1.0	700	
05D471K	470 (423 ~ 517)	300	385	810	5	15	400	200	0.1	30	
07D471K				775	10	30	1250	600	0.25	70	
10D471K				775	25	70	2500	1300	0.4	150	
14D471K				775	50	125	4500	2500	0.6	320	
20D471K				775	100	220	6500	4000	1.0	620	
07D511K	511 (459 ~ 561)	320	415	845	10	33	1250	600	0.25	65	
10D511K				845	25	70	2500	1300	0.4	130	
14D511K				845	50	125	4500	2500	0.6	290	
20D511K				845	100	220	6500	4000	1.0	530	
10D561K	560 (504 ~ 616)	350	455	925	25	70	2500	1300	0.4	120	

STANDARD	VARISTOR VOLTAGE	MAX. CONTINUOUS VOLTAGE		MAX. CLAMPING VOLTAGE		ENERGY (J)	MAX. PEAK CURRENT 8/20 μ s (A)		Rated Power	Capacitance (Reference) (1KHZ)	
		V	Acrms (V)	DC (V)	Vc (V)		Ip (A)	10/1000 μ s			1time
14D561K					925	50	125	4500	2500	0.6	260
20D561K					925	100	220	6500	4000	1.0	480
10D621K	620 (558 ~ 682)	385	505		1025	25	70	2500	1300	0.4	110
14D621K					1025	50	125	4500	2500	0.6	240
20D621K					1025	100	220	6500	4000	1.0	450
10D681K	680 (612 ~ 748)	420	560		1120	25	70	2500	1300	0.4	100
14D681K					1120	50	130	4500	2500	0.6	230
20D681K					1120	100	230	6500	4000	1.0	440
10D751K	750 (675 ~ 825)	460	615		1240	25	75	2500	1300	0.4	90
14D751K					1240	50	143	4500	2500	0.6	220
20D751K					1240	100	255	6500	4000	1.0	420
10D781K	780 (702 ~ 858)	485	640		1290	25	75	2500	1300	0.4	85
14D781K					1290	50	150	4500	2500	0.6	220
20D781K					1290	100	265	6500	4000	1.0	410
10D821K	820 (738 ~ 902)	510	670		1355	25	85	2500	1300	0.4	80
14D821K					1355	50	157	4500	2500	0.6	180
20D821K					1355	100	282	6500	4000	1.0	390
10D911K	910 (819 ~ 1001)	550	745		1500	25	93	2500	1300	0.4	70
14D911K					1500	50	175	4500	2500	0.6	170
20D911K					1500	100	310	6500	4000	1.0	360
10D102K	1000 (900 ~ 1100)	625	825		1650	25	102	2500	1300	0.4	65
14D102K					1650	50	190	4500	2500	0.6	150
20D102K					1650	100	342	6500	4000	1.0	330
10D112K	1100 (990 ~ 1210)	680	895		1815	25	115	2500	1300	0.4	60
14D112K					1815	50	213	4500	2500	0.6	140
20D112K					1815	100	383	6500	4000	1.0	310
14D182K	1800 (1620 ~ 1980)	1000	1465		2970	50	354	4500	2500	0.6	85
20D182K					2970	100	620	6500	4000	1.0	85

5. Dimension

	Range of voltage (V)	Dimensions (mm)			
		D max	T max	W \pm 1.0	d \pm 0.1
5D	18-68	7.5	4.0~5.2	5.0	0.6
	81-470	7.5	4.1~6.2	5.0	0.6
7D	18-68	8.5	4.1~5.4	5.0	0.6
	82-510	9.0	4.2~6.5	5.0	0.6
10D	18-68	12.5	4.3~5.5	7.5	0.8
	82-1100	13.5	4.3~9.7	7.5	0.8
14D	18-68	16.0	4.5~5.7	7.5	0.8
	82-1800	16.5	4.4~15.2	7.5	0.8
20D	18-68	23.0	4.7~6.0	10.0	1.0
	82-1800	23.5	4.8~15.5	10.0	1.0

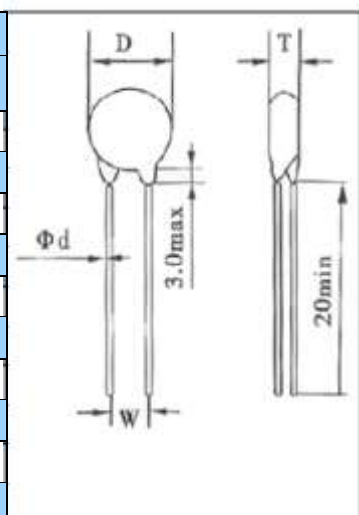

6. Precautions

The Varistor shall not be operated beyond the specified Ratings and Environmental Conditions in the Catalog or the Specifications to prevent them from deterioration, breakdown, flaming or glowing. Following “Precautions for Safety” and “Application Notes” shall be taken in your major consideration.

★ Precautions for Safety:

- The temperature of the working environment of the varistor must fall in the range required by technical conditions.
- The varistor shall not be operated exceeding the specified Maximum Allowable Voltage in the Catalog or the Specification.
- The Varistor shall not be operated beyond the “Maximum Peak Current Ratings” in the Catalog.
- It is recommended that the varistor shall be located 3mm away from other heat generating or combustible components.

★ Warning:

- When the varistor are applied between alive part and a metallic chassis of equipment, following safety countermeasures shall be taken to protect human from electric shock.
 - A) The metallic chassis shall be earthed to the ground.
 - B) A protective device against electric leakage must be installed in the equipment, or alternatively, a thermal type fuse should be attached closely to the varistor and series connected within its circuit.
 - C) The live part shall be equipped with a protective cover for preventing electric shock

• Protective Devices for Varistors

Precaution measures are to be taken against the accident damage

- 1) In case of “Across the Line Use”, the Varistor shall be protected by connecting a ground fault circuit interrupter or fusing in series to the devices.
- 2) In case of “Line to Ground Use” the short-circuit of the varistor may not blow the current type fuse due to the grounding resistance (between Line and Ground) which may cause flaming or burnout of the devices in the worst case. Following safety countermeasures (a or b) are recommended.
 - a) Connecting a “leakage current circuit breaker” in series to the varistor to be protected.
 - b) Use current type fuses and thermal type fuse which are thermally coupled with the varistor each other.

• Selection of Varistor Voltage Rating

1) General Precaution

In selection of Varistor Voltage Rating for line protection, following general precautions shall be taken in your consideration.

- A) Maximum operating voltage shall be lower than the specified “Maximum Allowable voltage” of the varistor applied.
 - B) In selection of the varistor, reasonable margin is required against fluctuation of the primary line (or circuit) voltage. Special consideration must be given to load unbalance of separately wired loads, short circuit between the live line and the neutral line or LC resonance at switching for a capacitive productive load.
- 2) Across-the-Line Use (Line to Line Surge Protection) select the varistor recommended in Table 1.

Notes:

For some electric equipments working under the phase voltage, the endurance of the short-time line voltage shall be taken into consideration during the design, and for such case, please select the varistor with “*”.

- 3) Line to Ground Use (Line to Ground Surge Protection) selects the varistor recommended in Table 1.

1 (Table 1)

Line - Line Surge Protection		Line - Ground Surge Protection	
Nominal Line Voltage	Part Number of varistor	Nominal Line Voltage	Part Number of varistor

Line – Line Surge Protection		Line – Ground Surge Protection	
AC100V	NFC XX D271	AC100V	NFC XX D821
AC120V	NFC XX D331	AC120V	NFC XX D821
AC220V	NFC XX D471	AC220V	NFC XX D182
	NFC XX D511		
	NFC XX D561*		
	NFC XX D681*		
AC380V	NFC XX D821	AC380V	NFC XX D182
	NFC XX D911		

Notes: XX: varistor diameter: 05, 07, 10, 14, 20

• Selection of Fuse Rating:

The recommended fuse locations are shown. For varistor protection, it is recommended to select suitable fuse in Table 2.

Varistor Series	05D	07D	10D	14D	20D
Recommended Fuse Ratings	1 – 2A	2 – 4A	3 – 5A	4 – 8A	6 – 10A

• Environmental Conditions

- 1) The varistor shall not be exposed outdoors, because of being designed for indoor use.
- 2) The varistor shall not be operated beyond the Specified Operating Temperature Range and shall not be exposed to direct sunlight and heating part of equipment.
- 3) The varistor shall not be operated under severe conditions of high temperatures and high humidities such as places exposed to rain, wind and vapour.
- 4) The varistor shall be free from dust, salty wind and atmospheres polluted by corrosive gas.

• Precautions for Assemblies and Handlings

- 1) Organic solvents such as thinner and acetone etc, shall not be applied to varistor for preventing deterioration of external coating or molding resin.
- 2) Abnormal mechanical stresses beyond the specified values such as strong falling shocks, vibrations and bending forces, shall be kept minimum to prevent electrical failures of the devices.

• Long Term Storage

- 1) The varistor shall not be stored under severe conditions of high temperatures and high humidities.
Store them indoors under 40°C max and 75% RH max. Use them within one year, if stored beyond the limit, check the solder bility before use.
- 2) The varistor shall not be stored under corrosive atmospheres such as hydrogen sulfide, sulfurous acid, chlorine and ammonia.
- 3) The varistor shall not be exposed to direct sunlight and shall not be stored under dew formation.

• Parallel Capacitance of the Varistor

The Parallel Capacitance of the Varistor is listed in the specification Table, for the designer's reference in high frequency circuit.

Technical Data

In the following experiments, all the characteristics, are experimented and obtained in compliance with the method and terms of GB/T 10195-1997 idt IEC 1051-2:1991 QC 420100. Specified indoor temperature: 25±5°C, comparative humidity: 45-85%, Atmospheric pressure: 86-106KPa.

Characteristics		Test Methods	Specifications
Varistor Voltage		The voltage between two leads varistor which is measured under the specified current, 05D series a specified current: 0.1mA , 07D, 10D, 14D, 20D series a specified current: 1mA.	To meet the Specified value
Maximum Allowable Voltage		The maximum sinusoidal RMS voltage or maximum DC voltage that can be applied continuously in the specified operating temperature range	
Clamping Voltage		The maximum voltage between two terminals with the specified standard impulse current(8/20 μ s) illustrated below applied	To meet the Specified value
Rated power		The maximum power that can be applied within the specified ambient temperature.	
Maximum Energy		Maximum energy from one or a burst of impulse. It is the value within the varistor Voltage of ± 10% when one impulse of 10-1000 μ s or 2ms is applied	To meet the Specified value
Maximum Peak Current	1 time	The maximum current within the varistor voltage change of ± 10% when a single standard impulse current of 8/20μs is applied.	To meet the Specified value
	2 times	The maximum current within the varistor voltage change of ± 10% when a standard impulse current of 8/20 μ s is applied two times with an interval of 5 minutes.	
Temperature Coefficient of Varistor voltage		$\frac{V_c(+85^\circ\text{C}) - V_c(+25^\circ\text{C})}{V_c(+25^\circ\text{C})} \times \frac{1}{60} \times 100\%$	0~-0.05%/°C
Capacitance		Testing condition : 1KHz ± 10%. 1Vrms. (1MHz ± 10% below 100PF)	To meet the Specified value
Insulation Strength (Body Insulation)		The specified voltage shall be applied between both terminals of the specimen connected together and metal foil closely wrapped round its body for 1 minute.	
		Varistor voltage	Testing Voltage (AC)
		Vc≤330V	1000Vrms
		Vc>330V	2000Vrms
Impulse Life		The change of Vc shall be measured after the impulse current. Listed with the interval of 2 min when 10~1000 impulses are applied or the 10 seconds interval when 10000-100000 impulses are applied.	ΔVc/Vc≤±10%
Terminal Pull		After gradually applying the load specified below and.	No outstanding damage
Strength		Keeping the load fixed for 10 seconds. The change shall be measured and meet the requirement with no outstanding damage.	
		Terminal diameter	Force
		∅ 0.6mm, ∅ 0.8mm	10N
		∅ 1.0mm	20N
Terminal Bending Strength		The unit shall be secured with its terminal kept vertical and the weight specified below be applied in the axial direction. The terminal shall gradually be bent by 90° in one direction, then 90° in the opposite direction, and again back to the original position. The change shall be measured and meet the requirement with no outstanding damage.	
		Terminal Diameter	Force
		∅ 0.6mm, ∅ 0.8mm	10N
		∅ 1.0mm	20N
		Subjected to simple harmonic motion of 0.75mm amplitude	

Vibration	1.5mm maximum total excursion between limits of 10-55Hz. Frequency scan shall be traversed in one minute, This motion shall then be applied for period of two hours in each of three mutually perpendicular directions. The change shall be measured and meet the requirement with no outstanding damage.	No Outstanding Damage																		
Solder ability	After dipping the terminal to a depth of approximately 2mm from the body in a soldering bath of 235±5°C for 2±0.5°C sec. The terminations shall be uniformly tinned.	Approximate 95% of the terminals shall be covered with new solder uniformly																		
Resistance to Soldering Heat	The terminal shall be dipped into a soldering bath with temperature of 260±5°C to a point of 2-2.5mm from the body for 10±0.5sec. (05D shall be 5 ± 1sec.) and then stored at room temperature and humidity for 1-2 hours. The change of Vc shall be measured and meet the requirement with no outstanding damage.	$\Delta V_c/V_c \leq \pm 5\%$, No Outstanding Damage																		
High Temperature Storage/ Dry Heat	The specimen shall be subjected to 125±2°C for 1000 hours in a drying oven without load and then stored at room temperature for 1-2 hours. The change of Vc shall be measured and meet the requirement with no outstanding damage.	$\Delta V_c/V_c \leq \pm 5\%$																		
Humidity	The specimen shall be subjected to 40°C, 90 to 95% R.H.	$\Delta V_c/V_c \leq \pm 5\%$																		
	For 1000 hours without load and then stored at room temperature for 1-2 hours. The change of Vc shall be measured and meet the requirement with no outstanding damage.																			
Temperature Cycle	Temperature cycle operation of the following table shall be repeated 5 times continuously. And then the specimen shall be left at room ambient for 1-2 hours. The change of Vc shall be measured and meet the requirement with no outstanding damage.	$\Delta V_c/V_c \leq \pm 5\%$ No Outstanding Damage																		
	<table border="1"> <thead> <tr> <th>Stops</th> <th>Temperature (°C)</th> <th>Time (min)</th> <th>Steps</th> <th>Temperature (°C)</th> <th>Time (min)</th> </tr> </thead> <tbody> <tr> <td>1</td> <td>-40±3</td> <td>30±3</td> <td>3</td> <td>125±2</td> <td>30±3</td> </tr> <tr> <td>2</td> <td>Rom Temperature</td> <td>15±3</td> <td>4</td> <td>Rom Temperature</td> <td>15±3</td> </tr> </tbody> </table>		Stops	Temperature (°C)	Time (min)	Steps	Temperature (°C)	Time (min)	1	-40±3	30±3	3	125±2	30±3	2	Rom Temperature	15±3	4	Rom Temperature	15±3
	Stops		Temperature (°C)	Time (min)	Steps	Temperature (°C)	Time (min)													
1	-40±3	30±3	3	125±2	30±3															
2	Rom Temperature	15±3	4	Rom Temperature	15±3															
High Temperature Load/Dry Heat Load	After being continuously applied the maximum allowable voltage at 85±2°C for 1000 hours, the specimen shall be stored at room temperature and humidity for 1-2 hours. The change of Vc shall be measured and meet the requirement with no outstanding damage.	$\Delta V_c/V_c \leq \pm 10\%$																		
Damp Heat Load/Humidity Load	After being continuously applied the maximum allowable voltage at 85±2°C, 90-95% R.H. for 1000 hours, the specimen shall be stored at room temperature and humidity for 1-2 hours. The change of Vc shall be measured and meet the requirement with no outstanding damage.	$\Delta V_c/V_c \leq \pm 10\%$																		
Low Temperature Storage/Cold	Specimen shall be subjected to an ambient of -40±2°C for 1000 hours. And after the specimen shall be left at room ambient for 1-2 hours. The change of Vc shall be measured and meet the requirement. With no outstanding damage.	$\Delta V_c/V_c \leq \pm 5\%$																		

Advice to Customers

According to the agreed contract, ordered production can be provided to meet the customer's demand for product speciality in size, electronic parameter and other characteristics.